

Ref.No: RGUKT/Proc/Mech.Engg/MP/T12/E-2013, dated: 07.12.2013

BID DOCUMENT

Open Competitive Bid (OCB)

(e-Procurement)

For

**Supply and Installation of Equipments
To the Manufacturing Process Lab of Mechanical
Engineering Department
at the three campuses of
Rajiv Gandhi University of Knowledge Technologies**

Proprietary & Confidential



**RAJIV GANDHI UNIVERSITY OF KNOWLEDGE
TECHNOLOGIES**

Ground Floor, Vindhya C4 Building,

IIT-H Campus, Gachibowli

HYDERABAD- 500 032

Phone: 040-23001830

Proprietary & Confidential

No part of this document can be reproduced in any form or by any means, disclosed or distributed to any person without the prior consent of RGUKT except to the extent required for submitting bid and no more.

Contents

Description	Page No.
Newspaper advertisement	4
Time Schedule	5
Tender Form	6-7
Statement of important limits and values of bid	8-11
Tender Schedule	12-21
Requirement & Specifications	22-37
Financial Bid Statement	38
Bid Security Form	39
Performance Security Form	40
Supply Agreement Form	41-43
Bid letter form	44
Bidder Information Sheet	45
Turnover details, Major clientele details and specifications	46
Check List	47

News paper advertisement

E-Procurement Tender Notice

RAJIV GANDHI UNIVERSITY OF KNOWLEDGE TECHNOLOGIES



**Ground Floor, Vindhya C4 building, IIIT- H Campus,
Gachibowli, HYDERABAD- 500 032**

Phone: 040-23001830

Online tenders are hereby invited from reputed **manufacturer/ authorized representatives** for supply and installation of equipments for the following labs of Mechanical Engineering Department to the three RGUKT campuses located at Basar in Adilabad dist, Nuzvid in Krishna dist and R.K. Valley in YSR Kadapa dist, in AP.

- i. Metrology Lab
- ii. Manufacturing Process Lab
- iii. Applied Thermodynamics Lab I & II
- iv. Robotic Automation Lab

1. Tenderers can download the tender schedules from e-procurement Platform www.eprocurement.gov.in from 07.12.2013 onwards. Tenderers need to submit the bids separately for each lab online by uploading all the required documents through www.eprocurement.gov.in. **The last date for submission of tenders online is 26.12.2013 up to 05:00PM**

For further details regarding Tender Notification & Specifications please visit website: www.eprocurement.gov.in and www.rgukt.in

Date: 07.12.2013

**Sd/-
Registrar**

Time schedule of Tender related events
(Manufacturing Process Operations Lab)

Bid calling date	07.12.2013
Bid Document fee	Rs. 1,000/- (By way of DD from any Nationalized Bank)
Bid Documents Downloading Start date	07.12.2013
Bid Document Downloading End Date	25.12.2013 till 04:00 PM
Pre Bid Meeting	16.12.2013 at 04:00 PM
Last date for uploading documents online	26.12.2013 at 05:00 PM
Last date for Submission of documents (hard copies)	27.12.2013 at 04.00 PM
Technical Bid opening date/time	28.12.2013at 03:00 PM.
Price Bid opening date/time	30.12.2013at 03.00 PM
Contact person	Registrar, RGUKT
Reference No.	RGUKT/Proc/Mech.Engg/MP/T12/E-2013, dated 07.12.2013

Note: The dates stipulated above are firm and under no circumstances they will be relaxed unless otherwise extended by an official notification or happen to be Public Holidays. For the assistance in the online submission issues, the bidder may contact the help desk of M/s. Vayam Technologies (e-procurement) at their e-mail address: helpdesk.eproc@vayamtech.com

SECTION - I

INVITATION FOR BIDS

Reference: No: RGUKT/Proc/Mech.Engg/MP/T12/E-2013, dated **07.12.2013**

Subject: Tender for supply and installation of equipments to the Manufacturing Process Lab of Mechanical Engineering Department to the three campuses of RGUKT located at Basar (Adilabad Dist), Nuzvid (Krishna Dist) and RK Valley (Kadapa Dist) – Reg..

Sir/Madam,

- 1) Bids are invited on the e-procurement platform from the eligible manufacturers or their authorized distributors for supply and installation of equipments to the Manufacturing Process Lab of Mechanical Engineering Department to three campuses of RGUKT located at Basar (Adilabad Dist), Nuzvid (Krishna Dist) and R K Valley (YSR Kadapa Dist). The details of bidding conditions and other terms can be downloaded from the electronic procurement platform of Government of Andhra Pradesh i.e. www.eprocurement.gov.in
- 2) Bidders would be required to register on the e-Procurement market place “www.eprocurement.gov.in” and submit their bids online. On registration with the e-Procurement market place they will be provided with a user id and password by the system through which they can submit their bids online.
- 3) The bidders need to scan and upload the required documents as per the Check list given. Such uploaded documents pertaining to technical bid need to be attached to the tender while submitting the bids on line. The attested copies of all these uploaded documents of technical bid, signed undertaking of tenderer should be submitted off line to Registrar, RGUKT, Hyderabad by 04.00 PM of 27.12.2013 The RGUKT will consider only the bids submitted through on-line copies of the paper based bids.
- 4)
 - a) The participating bidder/s will have to pay tender processing fee (non-refundable) for the amounts specified in the Schedule of Requirements, in the form of Demand Draft drawn from any Nationalized Bank, in favour of Registrar, RGUKT, Hyderabad. Payable at Hyderabad.
 - b) Further the bidder/shall furnish, as part of it bid, the Bid security for the amounts specified in the Section-II of Tender Document be paid in the form of an unconditional and irrevocable Bank Guarantee issued by any Nationalized bank in the standard format as shown in the Tender Schedule or a crossed

Demand Draft drawn in favour of Registrar, RGUKT, Hyderabad along with bids.

- c) Further all the participating bidders have to electronically pay a non-refundable transaction fee to M/s. APTS, the service provider through "Payment Gateway Service on E-Procurement platform", as per the Government Orders placed on the e-procurement website.
- d) RGUKT will not accept the tenders from blacklisted companies or undependable Suppliers whose past performance with RGUKT was found poor due to delayed and/or erratic supplies and those with frequent product failures, and also against whom there have been adverse reports of Sub-Standard Quality / Poor Service of Equipment supplies, as defined in the other parts of the Bidding document.

For any clarification and further details on the above tender please contact Telephone No: 040-23001830 or Contact in Person during office hours.

SECTION-II

STATEMENT OF IMPORTANT LIMITS/VALUES RELATED TO BID

Item	Description
EMD	Rs. 1,00,000/- by way of Demand Draft from any Nationalized Bank or by way of irrevocable bank guarantee from any Nationalized Bank only. DD/BG from other than Nationalized Banks will not be accepted.
Bid Validity Period	360 days from the date of opening of Financial bid
EMD Validity Period	90 days from the date of opening of Financial bid
Warranty Period	3 years Comprehensive Warranty
Variation in quantities/number of residents	± 40 %
Period for furnishing performance Security Deposit	Within 15 days from date of receipt of award
Delivery Schedule	Bidder shall deliver the goods in one single lot within 90 days from the date of award of the contract.
Performance security value	10% of contract value by way of irrevocable Bank Guarantee in case of imported equipment.
Performance security validity period	38 months from award of contract (including 30 days of installation period)
Period for signing the order Acceptance	Within 15 days from date of receipt of notification of award

PAYMENT TERMS	
On delivery at user site	<p>Payment for goods and services shall be made in Indian rupees or equivalent value in foreign currency.</p> <ol style="list-style-type: none"> 1. 80% of payment will be paid after installation, commissioning 2. Balance 20% will be paid after 3 months after obtaining the satisfactory certificate from the Director, RGUKT IIITs 3. In case of equipment from foreign country LC will be opened for 100% and 90% of payment will be paid on delivery & submission of documents and remaining 10% will be paid after installation and commission.
Maximum Liquidated Damages for late deliveries	<p>For delays:- If the supplier fails to deliver any (or) all of the goods or perform the services within the time period specified in the contract the purchaser shall without prejudice to its other remedies under the contract deduct from the contract price as liquidated damages a sum equivalent to 0.25% of the contract value per day until actual delivery or performance up to a maximum deduction of 10% of the delayed goods or services contract price. Once the maximum deduction is reached, the purchaser may consider the termination of the contract duly forfeiting the performance security etc.,</p>
Placing work order	<ul style="list-style-type: none"> ➤ RGUKT will place order on identified successful bidder. ➤ All the payments shall be made directly by RGUKT to the successful bidder as per the tender terms and conditions. ➤ If decided RGUKT can split the order basing on the quoted price and service track record. The decision of RGUKT is final in this regard.
Transaction Fee	<p>Transaction fee: All the participating bidders who submit the bids have to pay an amount @ 0.03% of their final bid value online with a cap of Rs. 10,000/-</p>

	for quoted value of purchase up to Rs.50 crores and Rs.25000/- if the purchase value is above Rs.50 crores & service tax applicable @ 12.36% as levied by Govt. of India on transaction fee through online in favour of MD, APTS. The amount payable to APTS is non refundable.
Transaction Fee Payable to	The Managing Director, A.P. Technology Services Ltd., Hyderabad
Bid submission	Online. Bidders are requested to submit the bids after issue of minutes of the pre bid meeting duly considering the changes made if any, during the pre bid meeting. Bidders are totally responsible for incorporating/complying the changes/amendments issued if any during pre bid meeting in their bid.
Procedure for Bid Submission	Bids shall be submitted online on www.eprocurement.gov.in platform <ol style="list-style-type: none"> 1. The participating bidders in the tender should register themselves free of cost on e-procurement platform in the website www.eprocurement.gov.in 2. Bidders can log-in to e-procurement platform in Secure mode only by signing with the Digital certificates. 3. The bidders who are desirous of participating in e-procurement shall submit their technical bids, price bids as per the standard formats available at the e-market place. 4. The bidders should scan and upload the respective documents in Pre-Qualification and Technical bid documentation including EMD. The bidders shall sign on all the statements, documents certificates uploaded by them, owning responsibility for their correctness/authenticity. 5. The hard copies of all the uploaded Technical / Price bid, to be attested by a Gazetted Officer or

	<p>properly notarized.</p> <p>6. The rates should be quoted in online only</p>
<p>Other conditions</p>	<p>1. After uploading the documents, the copies of the uploaded technical bid documents, for evaluation and original Demand Drafts in respect of Bid Security and Bid document fee are to be submitted by the bidder to the “The Registrar, RGUKT, Vindhya-C4 Building, IIIT Campus, Gachibowli, Hyderabad-32”, by 04:00PM on 27.12.2013.</p> <p>Failure to furnish any of the uploaded documents, certificates, will entitled in rejection of the bid. The RGUKT shall not hold any risk on account of postal delay. Similarly, if any of the certificates, documents, etc., furnished by the Bidder are found to be false / fabricated / bogus, the bidder will be disqualified, blacklisted, action will be initiated as deemed fit and the Bid Security will be forfeited.</p> <p>2. RGUKT will not hold any risk and responsibility regulating non-visibility of the scanned and uploaded documents.</p> <p>3. The Documents that are uploaded online on e-market place will only be considered for Bid Evaluation.</p> <p>4. Important Notice to Contractors, Suppliers and Department users (i) In the endeavor to bring total automation of processes in e-Procurement, the Govt. has issued orders vide G.O.Ms.No. 13 dated. 5.7.2006 permitting integration of electronic Payment Gateway of ICICI/HDFC/Axis Banks with e-Procurement platform, which provides a facility to participating suppliers / contractors to electronically pay the transaction fee online using their credit cards.</p>

SECTION-III

TENDER SCHEDULE

1. PREAMBLE:

The Registrar, Rajiv Gandhi University of Knowledge Technologies (RGUKT), Hyderabad invites tenders for supply and installation of equipments of Manufacturing Process Lab of Mechanical Engineering Department to its three campuses located at Basar (Adilabad District), Nuzvid (Krishna District) and RK Valley (YSR Kadapa District), through e-procurement platform.

2. SCOPE OF WORK

Supply and installation of equipments of Manufacturing Process Lab of Mechanical Engineering Department equipments to the three campuses of RGUKT located at Basar (Adilabad Dist), Nuzvid (Krishna Dist) and R K Valley (YSR Dist).

3. EARNEST MONEY DEPOSIT / SECURITY DEPOSIT:

3.1 The tender should be accompanied by Earnest Money Deposit (EMD) for **Rs. 1,00,000/-** by way of crossed Demand Draft/ Bank Guarantee issued/ drawn from any Nationalized Bank in favor of "Registrar, RGUKT" payable at Hyderabad. Tenders received without EMD will be summarily rejected.

3.2 Forfeiture of the EMD will be made in the following events:

3.2.1 Withdrawal of bid during the bid validity period.

3.2.2 In case of successful bidder, if the bidder fails to sign the contract in time or fails to submit performance guarantee.

4. PERFORMANCE SECURITY:

4.1 The successful bidder has to deposit 5% for indigenous equipments and 10% in case of imported equipment (foreign origin) of the total contract value as performance security deposit in the form of Bank Guarantee from any Nationalized Bank.

- 4.2 The Performance Security Deposit / Bank Guarantee of successful bidder will be retained for the period of contract in force and will be returned after expiry of contract, after deducting the outstanding liabilities if any.
- 4.3 The Performance Security Deposit / Bank Guarantee shall not carry any interest.

5 ELIGIBILITY CRITERIA

- 5.1 This bid is open to all firms within India who are eligible to do business under relevant Indian laws as in force at the time of bidding, subject to meeting the pre-qualification criterion. They should provide list of customers of previous supply of similar/ same items to IITs, NIT's or Central Universities or any Academic Institute of National repute with contact details. Copies of orders received from the reputed firms on bidding firm need to be submitted.
- 5.2 The bidder should have servicing facility or work shop with in India so the provision of service is possible at a short notice and without incurrance of delay.
- 5.3 The Bidding firm should have minimum turnover as follows:

Bid Value offered against the tender call	Last financial year's business turnover
Up to 25 lakhs	50 lakhs
More than 25 lakhs	1 crore

The bidder should have adequate experience in supply of such materials as required in the tender. Bidder should furnish proof of having supplied such materials as required in the tender in the previous financial year ending 31st March 2012 as mentioned above. A certificate indicating the Turn Over value details (in Rupees) of subject material, during the financial year 2012-13 (for the year ending 31.03.2013) from a Firm of Chartered Accountants must be enclosed (in original) as a proof for Turnover. The Turn Over of the subject Material must be separately indicated in the certificate.

- 5.4 The bidder should furnish satisfactory performance certificate from the parties concerned to whom bulk supplies were effected, in case such supplies were made. RGUKT may contact any such parties to elicit details.
- 5.5 Bidder should be registered under VAT Act/CST Act with the relevant State Sales Tax Authorities. He should furnish along with the bid document, the relevant VAT/CST Registration Document and PAN / TAN Card copies.
- 5.6 All bidders shall also include the following information and documents with their tenders (in the Technical bid cover)
- 5.6.1 Copies of original documents defining the constitution or legal status, place of registration, and principal place of business of the bidding firm/entity; written power of attorney of the signatory of the Bid to commit the Bidder.
- 5.6.2 Machinery/equipment owned by the bidder and number of employees.
- 5.6.3 Latest Income Tax returns and **VAT/ CST** Returns filed.
- 5.6.4 List of Present Clientele with contact addresses & telephone numbers.
- 5.7 All the certificates furnished along with technical bids should be attested by a Gazetted Officer, counter signed by bidder along with their seal.

The bidders must submit all relevant documentary evidence to support their claim for eligibility in placing bid. **The tenders received without the above documents will be rejected.**

6. INSTRUCTIONS TO BIDDERS

- 6.1 Tenders with over writings, alterations etc., will not be admitted unless they are attested by the bidder. Where there is a discrepancy between the amount (Rupees) in figures and words, the price, which is least of the two, will prevail.
- 6.2 Bid should be strictly in conformity with the Terms and Conditions mentioned in the tender schedule.
- 6.3 Bidders are expected to examine all the terms and instructions mentioned in the tender schedule and prepare their proposals accordingly. Failure to provide all requisite information will be at the bidders' own risk and may result in the rejection of the tender.
- 6.4 All assertions made in connection with the tender are to be supported / substantiated by relevant documents. The Registrar, RGUKT reserves

the right to verify the credentials of the bidder as per the eligibility criteria.

- 6.5 The Registrar, RGUKT will notify the bidder whose tender has been accepted.
- 6.6 The successful bidder shall execute an agreement with RGUKT on Non-judicial stamp paper worth Rs.100.00 agreeing to all the conditions of the contract 15 days upon intimation of acceptance of Tender. The successful bidder has to submit performance security guarantee after taking Letter of Intent but before having contract agreement. Failure on enter into an agreement within the stipulated time will result in forfeiture of the EMD.

The Registrar, RGUKT reserves the right to issue instructions / modifications at any point of time before award of contract.

7. METHOD OF SUBMISSION:

Bids shall be submitted online on www.eprocurement.gov.in Platform.

- 7.1. The participating bidders in the tender should register themselves free of cost on e-procurement platform in the website www.eprocurement.gov.in
- 7.2. Bidders can log-in to e-procurement platform in Secure mode only by signing with the Digital certificates.
- 7.3. The bidders who are desirous of participating in e-procurement shall submit their technical bids, price bids as per the standard formats available at the e-market place.
- 7.4. The bidders shall sign on all the statements, documents certificates uploaded by them, owning responsibility for their correctness/authenticity.
- 7.5. The bidders should scan and upload the respective documents in Technical Documentation as per the check list.
- 7.6. After uploading the documents, the copies of the uploaded technical bid documents, and original Demand Drafts in respect of Bid

Security and Bid document fee are to be submitted by the bidder to the “The Registrar, RGUKT, Vindhya-C4 Building, IIIT Campus, Gachibowli, Hyderabad-32”, by **4:00PM on 27.12.2013.**

- 7.7. Failure to furnish any of the uploaded documents, certificates, will entitled in rejection of the bid. The RGUKT shall not hold any risk on account of postal delay. Similarly, if any of the certificates, documents, etc., furnished by the Bidder are found to be false / fabricated / bogus, the bidder will be disqualified, blacklisted, action will be initiated as deemed fit and the Bid Security will be forfeited.
- 7.8. RGUKT will not hold any risk and responsibility regulating non-visibility of the scanned and uploaded documents.
- 7.9. The Documents that are uploaded online on e-market place will only be considered for Bid Evaluation.
- 7.10. Important Notice to Contractors, Suppliers and Department users (i) In the endeavor to bring total automation of processes in e-Procurement, the Govt.has issued orders vide G.O.Ms.No. 13 dated. 5.7.2006 permitting integration of electronic Payment Gateway of ICICI/HDFC/Axis Banks with e-Procurement platform, which provides a facility to participating suppliers / contractors to electronically pay the transaction fee online using their credit cards.

In case of consortium either the prime bidder or the consortium partner can purchase the bid document. The bid can be filed either with user ID of prime bidder or consortium partner.
- 7.11. The rates should be quoted online only.

8 EVALUATION PROCEDURE:

- 8.1 The Tenders will be opened on 28.12.2013. at 03:00 PM by the Registrar, RGUKT or his authorized representative in the presence of the bidders or their authorized representative who may be present at that time.

- 8.2 The Technical Bids will be opened on 28.12.2013. at 03.00 PM. The tenders will be evaluated so as to ascertain the capability of the bidders to provide the material within the period mentioned above and also to assess whether the bidder satisfies the eligibility criteria as detailed in Clause 5 above.
- 8.3 The rejection of the bidder on technical grounds will be based on the failure to meet eligibility requirements.
- 8.4 The committee may reject a bid for non conformance of the specifications.
- 8.5 Price Bid of only those bidders, who have fulfilled the eligibility criteria specified in Clause '5', 8.2 and 8.4 above, will be considered and who does not fulfill the eligibility criteria will not be considered and their tender rejected.
- 8.6 Any claims or disputes raised by the unsuccessful bidders in respect of selection process and non-allotment of award will have no legal validity and will not be enforceable against the RGUKT. No further correspondence will be entertained regarding the disqualification.
- 8.7 The Registrar, RGUKT reserves the right to accept or reject any / or all the tenders without assigning any reasons whatsoever. The Registrar, RGUKT also reserves the right to cancel the selection process for award of the contract at any time. The decision of the Registrar, RGUKT is final and binding.

9. PENALTY CONDITIONS :

- 9.1. 0.25% will be deducted from total value of the order for each day of delayed supply, and maximum of 10% will be deducted, if delay continues

beyond 10% the contract is liable for termination. If contract is terminated the bidder forfeits the performance security Deposit etc.,

(NOTE: Delivery and installation must be made in a single lot within the delivery date agreed at the time of award of contract)

- 9.2. If the contract is terminated, as per clause 9.1 above the performance security will be en-cashed by Registrar, RGUKT and the bidder forfeits it.
- 9.3. In case after random check of equipment of the supplied lot, if it is found to be non conforming to the technical specifications then entire lot of such equipment will be rejected. In this case the Registrar, RGUKT shall encash the performance security deposit. The bidder shall have no claim to any payment towards the transaction.

10. VALIDITY OF THE CONTRACT

The contract quoted bid price shall remain valid for a period of 365 days from the date of issue of purchase order.

11. GENERAL TERMS & CONDITIONS

- 12.1. The supply, installation and Commissioning of equipments of Manufacturing Process Lab of Mechanical Engineering Department shall be at the three IITs under the RGUKT located at
 1. Basar, Adilabad District
 2. Nuzvid, Krishna District
 3. R K Valley (Idupulapaya), Kadapa District

- 12.2. Goods are to be supplied as per the specification and quantity. Details are annexed to this bid document.

12.3. Delivery and distribution:

General Clause: The goods need to be supplied (in case of equipment need to be installed and commissioned) within the stipulated time agreed upon in the contract.

If no such clause exists in the contract, this period may be treated as 90 days from the signing on Supply Agreement Form.

Bidder shall deliver the goods in one lot within 90 days from the date of award of the contract.

- 12.4. All goods/ equipment supply shall carry a comprehensive warranty period of 3 years. Within the warranty period, in case of any damage to the supplied material like breakage, wear and tear, Electronics defects etc, it will be the responsibility of the supplier to trouble shoot, rectify and restore functioning or replace the damaged material within 7 working days.
- 12.5. A random sample of any item will be picked from the lot of items delivered by the bidder to the three campuses of RGUKT. This sample will be subjected to tests, if necessary at labs anywhere in the country to ensure compliance to specifications. If the result indicates non conformance, the entire lot will be rejected and the contract will stand terminated without any liability on the part of RGUKT. In addition, this event shall lead to the forfeiture of the performance security amount.

13. DISPUTES:

All disputes and differences of any kind whatsoever arising out of or in connection with the contract, whether during or after completion of contract will be settled at Hyderabad only, amicably in a spirit of co - operation and the RGUKT's decision shall be final on all such matters and shall be binding on the Bidder.

14. DISCLAIMER:

- 14.1. Even though adequate care has been taken in the preparation of this Tender Schedule the Bidder should satisfy himself that the Schedule is complete in all respects.
- 14.2. Neither RGUKT nor its employees make any representation or warranty as to the accuracy, reliability or completeness of the information in this tender schedule and it is not possible for the RGUKT to consider the investment objective, financial situation and particular needs of each party who reads or uses the Tender Schedule. Certain prospective Bidders may have a better knowledge of the scope of work than others. Each prospective Bidder should conduct his or her own investigations and analysis and check the accuracy, reliability and completeness of the information in the Tender schedule and obtain independent advice from appropriate sources.
- 14.3. Registrar, RGUKT reserves the right to reject any or all the Bids submitted in response to this request for Proposal at any stage without assigning any reasons whatsoever.
- 14.4. Registrar, RGUKT reserves the right to change any or all of the provisions of this tender Proposal.

15. REJECTION OF TENDERS:

- 15.1. The Registrar, RGUKT reserves the right to cancel the tender process and reject all tenders at any time prior to the award of contract without thereby incurring any liability as against the affected bidder or any obligations to inform the affected bidder of the grounds of acceptance or rejection.
- 15.2. No bidder is entitled to withdraw his or her offer after submission. In case of such withdrawal, the EMD deposited along with the tender schedule shall stand forfeited.
- 15.3. For breach of any of the conditions prescribed in the tender or as specified by the RGUKT from time to time, the EMD is liable to be forfeited. Decision of the Registrar, RGUKT in this regard is final and binding on bidders.

16. Requirement :

The following Manufacturing Process Lab equipments are required in the specifications mentioned here under for all the three Campuses of RGUKT located at Basar (Adilabad District), Nuzvid (Krishna District), RK Valley(YSR District)

Requirement for Manufacturing Process Lab

S.No	Item	Qty Required
1.	Universal Milling Machine	3
2.	Hydraulic Power Press	3
3.	Automated MIG Welding System	3
4.	Automated TIG Welding System	3
5.	Spot Welding Machine	3
6.	Equipment for Arc Length Measurement	3
7.	Sand Testing Equipment	3
8.	Radial Drilling Machine	2
9.	CNC Wire Cut EDM	3

1. Specifications of Universal Milling Machine:

Table:

Overall dimension (length x width)	2050 x 300mm ²
Clamping area (length x width)	1600 x 300mm ²
T-slots No./Width/Centre distance	3/18mm/100mm
Swivel range of table on both sides	45 degrees
Maximum safe weight on table	600kg

Milling spindle:

Milling spindle front bearing diameter	95mm
Spindle taper	50ISO
No. of speeds	18
Speed range	35-1800rpm

Feeds:

No. of feeds	20 or above
--------------	-------------

Feed range:

Longitudinal & cross	16-1600mm/min
Vertical	6.3-630mm/min

Rapid traverse:

Longitudinal & cross	2000mm/min
Vertical	800mm/min

Milling spindle motor

7 kW or above

Feed motor

2kW or above

Special accessories:

Machine vice Swivel base 150mm	1 no
Universal dividing head with set of change gears and Chuck & tailstock support --	1no
Hand operated circular table 400 mm --	1no
Long arbor diameter 16, 22, 27 and 32 mm	1 each

With following addition for safety and ease of operation

Photoelectric safety guard

Bigger size PLC with Touch Screen display

Encoder should be provided for the precise stroke measurement & stroke control. Encoder should be sensing through PLC & analog card & display in TOUCH SCREEN. The accuracy/least count of encoder should be at least 0.1 mm.

Load cell for main cylinder should be provided to sense the load through PLC and Analog Card with Digital Display of Load in TOUCH SCREEN. The least count & Load Cell should be at least 0.01 Ton.

Load cell to find out blank holder load should be provided with least count of 0.01 Ton.

Pressure transmitter should be provided for sensing the pressure of main cylinder and blank holder cylinder through PLC & ANALOG CARD with digital display of pressure in TOUCH SCREEN.

It should be interfaced with a computer to get the load displacement curve and data file in XL Format so that one can take the data and plot the curves.

3. Automated MIG Welding System

Metal Inert Gas(MIG) welding system should consists of

1. One tractor mounted MIG welding torch. With Variable speed the tractor should move during welding.
2. One clamping arrangement for job with motorized slide to travel the job with variable speed.
3. Control panel to adjust the travel speed of tractor & motorized slide, speed display, welding On/Off.
4. MIG welding power source, MIG welding torch mounted on tractor, MIG wire feeder.

TECHNICAL SPECIFICATIONS FOR MIG WELDING MACHINE

Mains Voltage,	Ph x V, 3x400, 50Hz
Fuse slow,	A 25
Setting range, MIG/MAG,	Amps / Volts: 16-400 A / 8-60 V
Setting range, MMA DC,	A 16-400
Setting range, TIG DC,	A 4-400
at 35% duty cycle MMA,	A/V 400/36
at 60% duty cycle MMA,	A/V 320/33

at 100% duty cycle MMA,	A/V 250/30
Open circuit voltage ,	V 55-90
Energy save mode	(400V), W 60 50
Apparent power,	kVA 18.6
Power factor at maximum current	0.9
Efficiency at maximum current,	%86
Control voltage	42v, 50/60 Hz
Dimensions l x w x h, mm	625x394x496
Enclosure class	IP23
Insulation class:	H
Operating temperature, °C	-10 to +40
Weight, kg	63.5
Application class S Standards	IEC/EN 60974 -1,

SPECIFICATIONS OF WIRE FEEDER

Technical Data

Mains supply,	Ph x V, Hz 1 x 42
Drive system	4- Roll Drive
Max. Diameter of wire spool,	Mm 330 / 440
Wire feed speed, m/min	0.8 to 25M/min
Wire type	MS / Al / FC
Wire diameter	0.6 to 1.6mm
Enclosure class	IP23
Standards of compliance	IEC/EN 60974 -5/-10
Weight, Kg	15kg
Cooling System	Forced air cooling/Water
cooling	

SPECIFICATIONS OF MIG TORCH

Torch Type	GMAW Welding
Type of Cooling	Air or Cooling gas
Torch Cable length	4 meters
Tool Kit consisting of Nozzle Cleaner, Alley keys, Plier for cutting wire	

SPARES AND ACCESSORIES

ITEM	QUANTITY
Feed Roll	2 (0.6/0.8 mm hard & 0.9/1.2 mm hard)
Collet Body	5

Collet	5
Nozzle	4
Back Cap Long	5
Back Cap short	5
Argon Flow Meter Regulator	1
Argon Gas Cylinder	2
Wire Brush	5
Chipping Hammer	5
Hand Gloves	5
Apron	5
Auto darkening helmet DIN 9213	1
Ordinary welding helmet	5
Welding Cable with Holder, 3m	1
Cylinder Key	2
Spanners	2
Filler wire for MS welding, 2sizes	2kgs (1kg each)
Filler wire for SS welding, 2sizes	2kgs (1kg each)
Filler wire for Al welding	1kg

CONCEPTUAL DESIGN OF THE AUTOMATED MIG WELDING SYSTEM

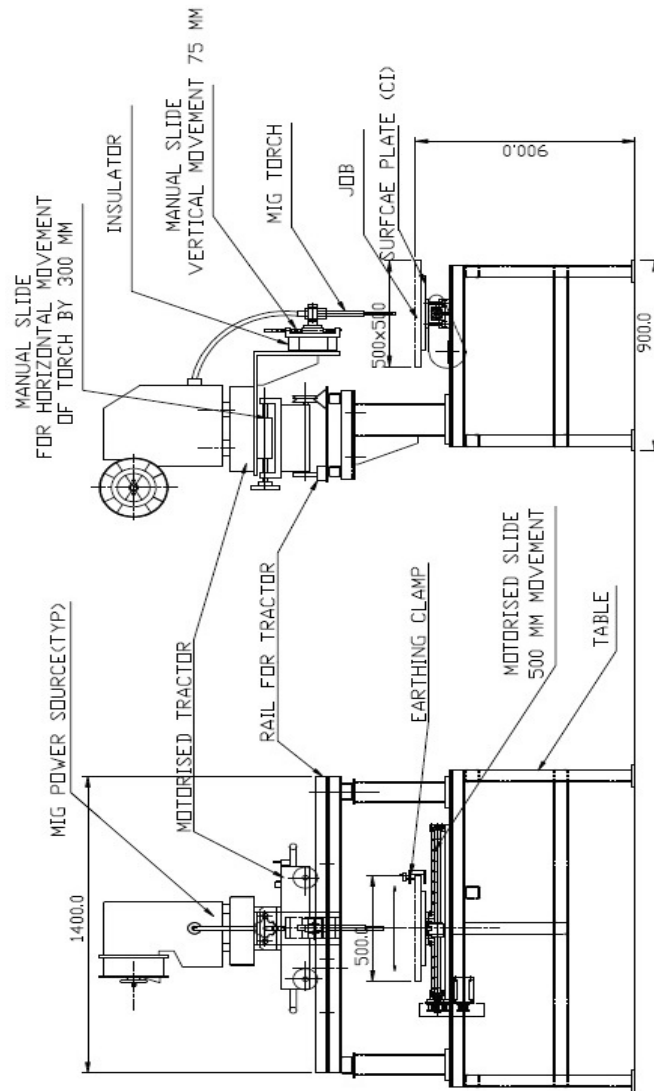

NOTE: Dimensions are approximate

1. Welding can be done in two modes, either by moving of the tractor, job remains stationary
2. Movement of job by motorized slide, torch on tractor remaining stationary.

4. Automated TIG Welding System

Tungsten Inert Gas(TIG) welding system should consists of

1. One tractor mounted TIG welding torch. With Variable speed the tractor should move during welding.
2. One clamping arrangement for job with motorized slide to travel the job with variable speed.
3. Control panel to adjust the travel speed of tractor & motorized slide, speed display, welding On/Off.

4. TIG welding power source, TIG welding torch mounted on tractor, TIG wire feeder.

Note: The TIG machine should also join Aluminum alloys by varying the AC power.

TECHNICAL SPECIFICATION FOR TIG WELDING MACHINE

Input Supply	400V, 3ph, 50Hz
Mains Cable	4x1.5Sq.mm
Fuse	20A (Slow)
Power in No - load	30 Watt
Open Circuit Voltage	54-64 Volts
Power Factor at 100% in TIG mode	0.72
Operating Temperature	-10 to +40 degree
C	
Enclosure Class	IP23C
Standards	IEC/EN 60974 – 1,
3,-10	
Insulation Class	H
Dimensions in mm LxWxH	652x412x423
Weight	42Kgs
Cooling System	Forced air cooling/Water
cooling	

Current setting range

MMA	16-300Amps
TIG	4-300Amps

Maximum output in AC/DC TIG

At 35% duty Cycle	300A/22V
At 60% duty cycle	240A/19.6V
At 100% duty cycle	200A/18V
Slope UP	0-10sec
Slope DOWN	0-10sec
Gas Post Flow	0-25sec
Pulse frequency DC	0.01-2.5sec
Frequency AC	10-150Hz
AC Balance	50-98%

TIG TORCHES – SPECIFICATION

Type of Cooling	Gas
Type of Connection	OKC – Quick
Connector	
Size of TIG rod,	1 - 4mm
Rating	A @ 35% 200

Length	4M
TIG torches conform to international standard	IEC/EN 60974-7

SPARES AND ACCESSORIES

ITEM	QUANTITY
Collet Body 2.4mm	5
Collet Body 3.2mm	5
Collet 2.4mm	5
Collet 3.2mm	5
Gas Nozzle Standard, 9.8mm	10
Gas Nozzle Standard, 11.2mm	10
Gas Nozzle Standard, 12.7mm	10
Tungsten Electrode 2.4mm	10
Tungsten Electrode 3.2mm	10
Back Cap Long	5
Back Cap short	5
Argon Flow Meter Regulator	1
Argon Gas Cylinder	2
Wire Brush	10
Chipping Hammer	5
Hand Gloves 1 pair Apron	5
Auto darkening helmet DIN 9213	2
Ordinary welding helmet	5
Welding Cable with Holder, 3m	1
Cylinder Key	2
Spanners	2
Filler wire for MS welding, 2 sizes	2kgs (1kg each)
Filler wire for SS welding, 2 sizes	2kgs (1kg each)
Filler wire for Al welding	1kg
Cold Wire Feeder mm	Suitable for 0.8, 1.0, 1.2, 1.4

CONCEPTUAL DESIGN OF THE AUTOMATED TIG WELDING SYSTEM

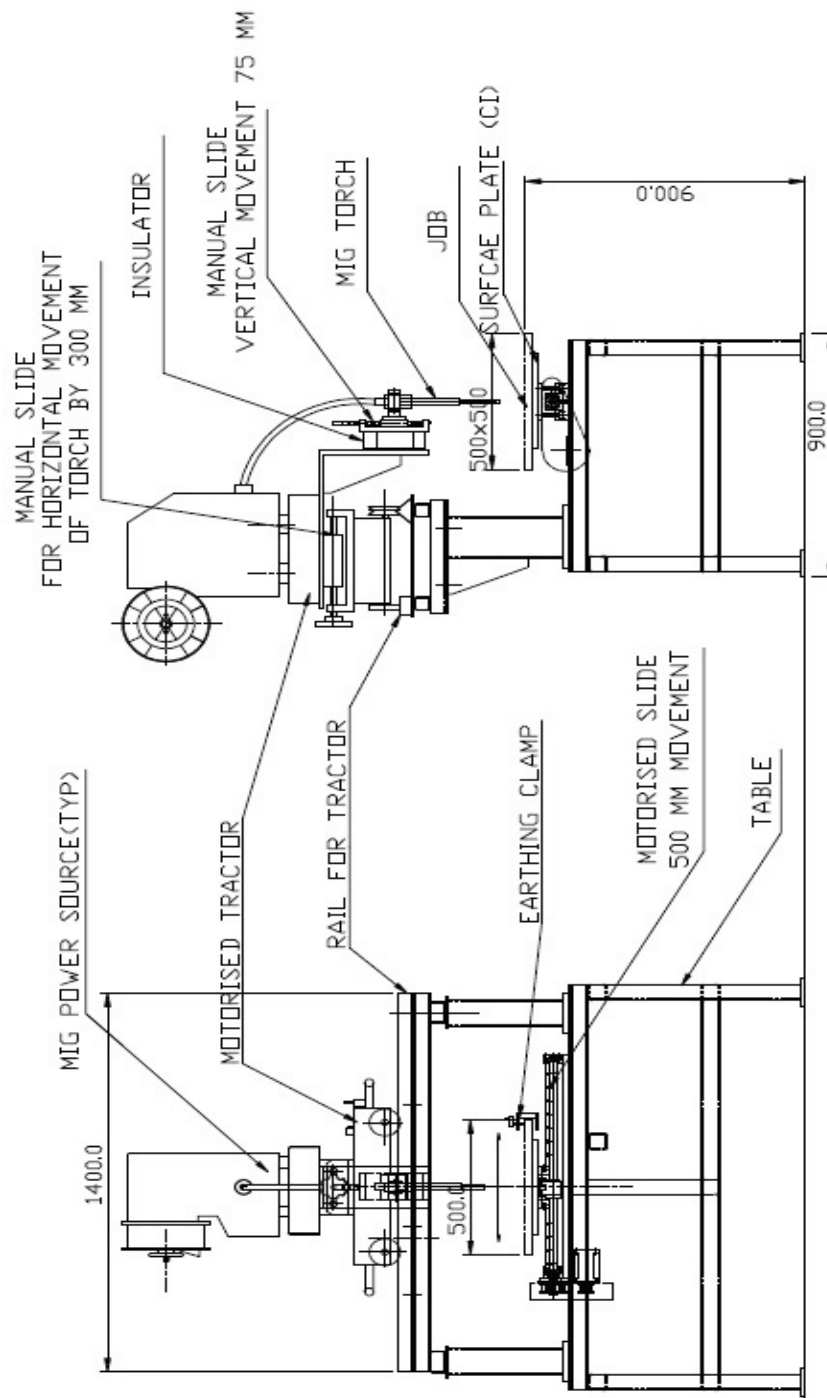

NOTE: Dimensions are approximate

1. Welding can be done in two modes, either by moving of the tractor, job remains stationary
2. Movement of job by motorized slide, torch on tractor remaining stationary.

5. Specifications of Spot Welding Machine:

Capacity	150 KVA @ 50% duty cycle
Throat depth	450-500 mm
Throat height	200 mm (adjustable)
Max. short circuit current	65,000 Amps.
Frequency	50 Hz
Main supply	415 Volts, 2 lines of three phase
Control unit power source	110 Volts AC
Stroke	150 mm (adjustable)
Electrode tip dia zirconium)	19 mm (beryllium copper & chromium zirconium)
Tip holder dia zirconium)	40 mm (beryllium copper & chromium zirconium)
Horn Diameter	100 mm (copper chromium zirconium)
Air-compressor starter	10 HP double cylinder type with motor and starter
Water tank/coolant tank	500 ltr S.S fabricated (with 1 HP)
Controller	Microprocessor based controller with constant Current facility (Secondary feedback)
Transformer efficiency	Modular (latest) Copper wound, high efficiency High output CRGO type, water cooled and epoxy encapsulated with thermostatic protection
Main cylinder dia	250 mm
F.R.L	½” BSP
Solenoid valve	½” BSP
Flow Control Valves	½” BSP
Surge Tank	30 liters
Foot-switch	Toe operated (electrical) low voltage
Differential switch	IPS70

Electrodes

Copper chromium zirconium electrode tips (50 nos)
Beryllium copper electrode tips (50 nos.)

6. Equipment for Arc Length Measurement

Technical Specifications:

01. LVDT with Digital Indicator

Range +/-20mm,
Resolution 0.01mm
4.5 digit LED display,
Mains operated
Mounting Clamp
Zero balance with Push Button throughout the range
Indicator Mounting Table top

02. Arc Image Magnifier

Magnification 10Times
Trolley Mounted wheel based
Minimum Height (Magnifier centre) 3.5feet
Vertical Height adjustment 150mm
Left to Right movement 100mm
Longitudinal movement 100mm
Angle Rotation (left to right) +/-10degree for Magnifier only
Angle Vertical Up and Down +/-10degree for Magnifier only

7. Sand Testing Equipment:

S.No	Item Description	Quantity required
1.	Sieve Shaker with Sieve Set Consists of sieving mechanism, to accommodate	3 No.

	<p>10 Nos sieves of 200mm Dia & 35 mm Height Supply: 1Ph 230 V 50 Hz AC Default Sieve set includes (Sizes in Microns) 1700, 850, 600, 425, 300, 212, 150, 106, 75, 53 Sieves, Lid & Receiving Pan. Timer: 0-15min. Motor - 1/8 Hp Single Phase, Cycles – 50,</p>	
2.	<p>Sand Muller Consists of one Muller, two ploughs, Rollers and basic accessories, Batch Capacity: 5 Kgs. Motor with Gear Box - ½ Hp Single Phase,</p>	3 No.
3.	<p>Sand Mixer Used to Mix core sand for testing purpose. Consists of two ploughs, Capacity - 10 Kg (Batch), Motor with Gear Box - ½ Hp Single Phase.</p>	3 No.
4.	<p>Rapid Moisture Meter Consists of single pan balance, spoon, 500gms of absorbent compound in polythene bottle, moisture meter capacity 10% complete in carrying case.</p>	3 No.
5.	<p>Sand Rammer Used for preparing a standard specimen of 50 mm Diameter 50 mm Height. It consists of 1) Calibrated sliding weight actuated by cam, 2) Specimen tube, 3) Cup and 4) Stripper</p> <p>Attachments: Base Block Tube Filter Tensile Core Box Transverse Core Box Split Specimen Tube Compatibility Tester Flowability Tester</p>	3 No.
6.	<p>Permeability Meter Consists of air tank, water tank, manometer unit, permeability chart, 2 Orifices, rubber seal and siphon unit.</p>	3 No.

	<p>Attachments: Mold Permeability Tester Core Permeability Tube</p>	
7.	<p>Universal Strength Machine Digital Consists of loading frame, loading mechanism, load cell, motor etc. Facility to accommodate various accessories, digital strength indicator, set of compression pad, compression range up to 15 kg/cm²,</p> <p>Attachments: High Dry Strength Attachments Shear Strength Attachments Tensile Strength Attachments Transverse Strength Attachments</p>	3 No.
8.	<p>Mould Hardness Tester Consists of dial indicator to read hardness of green mould from 0 to 100. Generally used for Hand ramming and/or jolt squeeze molding practice.</p>	3 No.
9.	<p>Digital Balance : Based on Load cell Technology Capacity : 300grms Accuracy: 0.01gm Pan Size: 125 mm Display: LED</p>	3 No.
10.	<p>ELECTRIC HOT AIR OVEN Chamber Size : 600 x 600 x 800 mm³ Max..Temp. : 300°c Controller : PID digital controller and cum Indicator with A sensitivity of +/- 2.deg.c Air circulation : fan 1 nos Triple walled chamber, Inner made out of S.S. 304 grade heavy gauge to withstand 300°C and outer made out of M.S. duly finished with Siemens white. The walls fitted with high grade glass wool with nickel chrome heating element.</p>	3 No.

8. Radial Drilling Machine

Technical Specifications	Size
Drilling Radius	500 – 1500 mm
Drilling in Steel	50 mm
Arm Traverse	650 – 800 mm
Feed Range	0.04 – 1.5 mm/rev (approx..)
Number of Spindle Speeds	12
Vertical Transverse	700 mm (Approx.)
Spindle motor power	5 kW or above
<p>Additional Box Table Universal Table Machine Lamp Base Plate Standard Drill sets with holders Any other basic accessories</p>	

9. CNC Wire-Cut EDM Machine

<u>Technical Specifications</u>		
S.No	Feature	Requirements
1	Description	A 4-axis CNC wire-cut EDM machine in a ready to use condition including appropriate accessories, software and control system.
2	Number of Axes	4-Axis (X,Y,u,v) simultaneous and independent with CNC control
3	Work table	Minimum: 400mm x 650mm (X x Y)
4	Traverses	Minimum: 275mm x 400mm (X x Y)
5	Max. work piece thickness	200mm or higher
6	Load capacity	200 kg or higher
7	Taper	± 20°/50mm or higher
8	Cutting speed	125 mm ² /min or better

9	Electrode wire diameter	0.25mm or thinner Quote for smaller wire diameters of 0.20mm & 0.15mm as an optional
10	Wire spool capacity	5kg or higher
11	Resolution	0.0005 mm
12	Least command input	0.0005mm
13	Least input increment	0.001mm or smaller
14	Control	A sophisticated part programming software with: 1) Simultaneous and independent 4-axis control 2) Window based editor 3) Capability of path generation and edit functions with DXF file as input 4) 3D graphic simulation while cutting 5) Complete set of drivers and interfaces required to plug and run on PC (with preferably USB port interface in place of 9/25 pin ports).
15	Dielectric unit	Dielectric: Preferably deionized water 1) Automatic deionising, filtration & flushing 2) Automatic dielectric conductivity monitoring 3) Dielectric cooling unit with differential temperature control 4) Mineral bed filtration as standard .
16	Power supply	AC 415V 50Hz 3-phase, Suitable servo stabilizer to be quoted under optional
17	Additional/optional features	Automatic shut off at wire breakage Automatic center and edge find Power failure protection function
18.	Packaging, insurance and transport	As per standard wooden packing (seaworthy packing etc.)
19.	Inspection, installation, commissioning and training	All the essential requirements ensuring ready to use set up at three different campuses of RGUKT
		Commissioning, job prove out as per the test charts and cutting performances
		Standard training at three different campuses of RGUKT
		One set of maintenance and operating manuals in English

		Consumable for installation and commissioning will be provided free of the cost with machine.
20.	Other conditions	Provision for pre-dispatch inspection if required. Separate prices should be shown for (a) basic equipment (b) essential accessories (c) optional accessories (d) normal spares particularly of the items which are likely to sustain damage or failure in use.

General terms and conditions to be followed by the suppliers/manufacturers

1. Any supplier / manufacturer is eligible to quote the rates for items partially or completely to which tenders are called for
2. While quoting the prices, it should be combined with prices of the accessories insisted in the specifications
3. Where ever additional accessories are essential to be quoted , however, allowed to do so by quoting separately
4. supplier / manufacturer should provide the clear data of utility requirement list
5. supplier / manufacturer should provide the instruction manual for both the experimental setups and instruments
6. supplier / manufacturer should provide the sample data & calculations and standard results for comparison in case of experimental setups

Financial Bid

Price Schedule for Goods offered

Please quote amounts in numerals and words at each place.

Sl. No	Name of the Equipment	Total Qty	Unit Price (In Rs) Without Taxes & Duties	Taxes & Duties on Unit Price	Unit Price (In Rs) With Taxes and Duties T(4+5)	Total Price (In Rs) (3*6)
1	2	3	4	5	6	7
1.	Universal Milling Machine	3				
2.	Hydraulic Power Press	3				
3.	Automated MIG Welding System	3				
4.	Automated TIG Welding System	3				
5.	Spot Welding Machine	3				
6.	Equipment for Arc Length Measurement	3				
7.	Sand Testing Equipment	3				
8.	Radial Drilling Machine	2				
9.	CNC Wire Cut EDM	3				

(Signature of Bidder)

Note: Please quote for imported equipments in Foreign Currency only. The exchange rate as on date of opening of the price bid will be applied and the comparative statement will be drawn in Indian Rupees. Wherever quoted in Indian Rupees such price will be considered for comparison.

ANNEXURE-1

RGUKT. Ref. No: *RGUKT/Proc/Mech.Engg/MP /T12/E-2013*

Bid Security(EMD) form

(To be issued by a Nationalized Bank in India and having at least one branch in Hyderabad)

Whereas.....(here in after called “ the Bidder”) has submitted its bid
Dated.....(Date). For the execution of(here in after called “the Bid”)

KNOW ALL MEN By these present that WE.....ofhaving our

Registered office at(hereinafter called the “Bank”) are bound unto
the Rajiv Gandhi University of Knowledge Technologies,. (hereinafter called “The RGUKT”) in
the sum offor which payment well and truly to be made to the said RGUKT itself,
its successors and assignees by these presents.

The conditions of these obligations are:

1. If the bidder withdraws its bid during the period of bid validity or
2. If the bidder, having been notified of the acceptance of its bid by the RGUKT during the period of bid validity
 - 1) Fails or refuses to execute the contract form if required; or
 - 2) Fails or refuses to furnish the performance security, in accordance with the bid requirement;

We undertake to pay the RGUKT up to the above amount upon receipt of its first written demand, without the RGUKT having to substantiate its demand, provided that in its demand the RGUKT will note that the amount claimed by it is due to it, owing to the occurrence of one or both of the two conditions, specifying the occurred condition or conditions. This guarantee will remain in force up to and including 45 days after the period of the bid validity, and any demand in respect thereof should reach the Bank not later than the above date.

Place:

Signature of the Bank

Date:

and seal.

ANNEXURE-II

RGUKT Ref. No: *RGUKT/Proc/Mech.Engg/MP/T12/E-2013*

PERFORMANCE SECURITY FORM

(To be issued by a Nationalized Bank in India and having at least one branch in Hyderabad)

To :.....(Address of RGUKT)

WHEREAS..... (Name of Vendor) hereinafter called “the Vendor” has undertaken, in pursuance of

Contract No.....Dated,.....(Date), to supply.....called “the Contract” AND WHEREAS it has been stipulated by you in the said Contract, that the Vendor shall furnish you with a Bank guarantee by a Nationalized bank for the sum specified therein as security for compliance with the supplier’s performance Obligations in accordance with the Contract.

WHEREAS we have agreed to give the Vendor a Guarantee:

THEREFORE WE hereby affirm that we are Guarantors and responsible to you, on behalf of the Vendor, up to a total of Rs.....and we undertake to pay you, upon your first written demand declaring the Vendor to be in default under Rs..... (Amount of Guarantee) as aforesaid without your needing to prove or to show grounds or reasons for your demand or the sum specified therein.

This guarantee is valid until theday of (Date)

Place:

Signature of Guarantors and Seal

Date:

ANNEXURE-III

SUPPLY AGREEMENT FORM

THIS AGREEMENT made the day of..... (Year).Between the Rajiv Gandhi University of Knowledge Technologies (hereinafter “the RGUKT”) of one part and..... (Name of Vendor) of..... (City and Country of Vendor) (Hereinafter “the Vendor”) of the other part:

WHEREAS the RGUKT is desirous that certain items as described in the bid document and briefly outlined below, should be provided by the Vendor.

Date of tender call:

Title of the project:

Brief outline of the work:

NOW THIS AGREEMENT WITNESSETH AS FOLLOWS:

In this agreement words and expression shall have the same meanings as are respectively assigned to them in the bid document referred to.

The following documents shall be deemed to form and be read and construed as part of this Agreement, viz.

1. bid documents
2. clarifications issued by RGUKT if any,
3. RGUKT notification of award.

In consideration of the payments to be made by the RGUKT to the Vendor as hereinafter mentioned, the Vendor hereby covenants with the RGUKT to provide the **items and to replace defective items during the warranty period** therein in conformity, in all respects, with the provisions of the contract.

The RGUKT hereby covenants to pay the Vendor in consideration of the provision of the items and **to replace defective items during the warranty period** therein, the contract price or such other sum as may become payable under the provisions of the contract at the times and in the manner prescribed by the contract.

Brief particulars of the items which shall be provided by the Vendor are as under:

Items	Quantity	Unit price (Inclusive of all taxes and duties)	Total Amount	Remarks

The Bidder further notes and accepts that:-

- Bidder shall deliver the goods in one single lot within 90 days for indigenous as well as imported equipments also from the date of award of the contract.

Payment terms	
On delivery at user site	<p>Payment for goods and services shall be made in Indian rupees as follows.</p> <ol style="list-style-type: none"> 1. 80% of payment will be paid after installation, and demonstrating of satisfactory functioning on site. 2. Balance 20% will be paid after 3 months after obtaining the satisfactory certificate from the Director, RGUKT IIIT. 3. In case of equipment from foreign country LC will be opened for 100% and 90% of payment will be paid on delivery & submission of documents and remaining 10% will be paid after installation and commission.
Maximum Damages for late deliveries	<p>For delays:- If the supplier fails to deliver any or all of the goods or perform the services within the time period specified in the contract the purchaser shall without prejudice to its other remedies under the contract deduct from the contract price as liquidated damages a sum equivalent to 0.25% of the contract value per day until actual delivery or performance up to a maximum deduction of 10% of the delayed goods or services contract price. Once the maximum deduction is reached, the purchaser may consider the termination of the contract duly forfeiting the performance security etc.,</p>

In addition if the contract is cancelled, the performance security will be en-cashed and forfeited.

- In case, after random sampling of the supplied lot, it is found that there is any non conformance to specifications, the performance guarantee will be en-cashed and forfeited and the bidder will have no claim to any payments. The entire lot will be rejected.

- The supply and distribution of Items supplied shall be done at all the three RGUKT campuses located at
 - Basar, Adilabad District
 - Nuzvid, Krishna District
 - R K Valley (Idupulapaya), Kadapa District

- There shall be a warranty period of 3 years and within the warranty period, in case of any damage to the supplied material like breakage, wear and tear, Electrical defects etc., it will be the responsibility of the supplier to make working the damaged material.
- A random sample of any size will be picked from the lot of items delivered by the bidder to the three IITs under the RGUKT. This sample will be subjected to tests, if necessary at labs anywhere in the country to ensure compliance to specifications. If the result indicates non conformance, the entire lot will be rejected and the contract will stand cancelled without any liability on the part of RGUKT. In addition, this event shall lead to the forfeiture of the performance security amount.
 - All disputes and differences of any kind whatsoever arising out or in connection with contract, whether during or after completion of contract will be settled amicably in a spirit of co – operation and the RGUKT decision shall be final on all such matters and shall be binding on the bidder.

IN WITNESS whereof the parties hereto have caused this Agreement to be executed in accordance with their respective laws the day and year above written.

Signed, and delivered by

Signed, and delivered by

For the Vendor.

For. Rajiv Gandhi University

Vendor's common seal:

of Knowledge Technologies

Place

RGUKT common seal:

Date:

Place:

Date:

In the presence of:.....

BID LETTER FORM

From:

(Registered name and address of the bidder)

To

Rajiv Gandhi University of Knowledge Technologies,

Ground floor, Vindhya C4 Building,

IIT-H Campuses, Gachibowli,

Hyderabad-500032.

Sir,

Having examined the bidding documents and amendments there on, we the undersigned, offer to supply and deliver the Manufacturing Process Lab (and other related materials) as the case may be, in conformity with the terms and conditions of the bidding document and amendments thereon in response to your tender call dated.....

We undertake to supply the above mentioned materials, as assigned to us in conformity with the said bidding documents, for an estimated sum of Rs (Total bid amount in words and figures) which may vary in accordance with the schedule of prices attached herewith and coverage options made by RGUKT or its user organization.

If our bid is accepted, we undertake to:

- a. supply the materials according to the time schedule specified in the bid document,
- b. Obtain the performance guarantee from a scheduled bank in accordance with bid requirements for the due performance of the contract, and
- c. Agree to abide by the bid conditions, which remain binding upon us during the entire bid validity period and the bid may be accepted any time before the expiration of that period.
- d. We understand that you are not bound to accept the lowest or any bid you may receive, nor to give any reason for the rejection of any bid, and that you will not defray any expenses incurred by us in bidding.

Place:

Bidder's Signature

Date:

Seal.

BIDDER INFORMATION

1	Name of the organization	
2	Year of establishment	
3	Registered Office Address	
4	Phone No.	
5	Fax No.	
6	Email	
7	Total No. of branch offices in AP	
8	Whether Manufacturer	Yes/No
9	Details of EMD furnished	
10	Details of certificates enclosed.	

Turn over details of item/product – 2012-13

S.No	Item name	Nos. sold	Amount (Rs in Lakhs)

List of Major Customers – 2012-13

S. No	Customer Full Address	Year of supply	Item Name	Turn Over (Rs. in Lakhs)

CHECK LIST

Important:

The Bidder must ensure that the following details in the check list are furnished along with the bid document. The bidder must also carefully go through all the contents of the BID Document and any additional information/documents, required more than the items listed in the check list below, also shall have to be furnished. Non-furnishing of any required information/document as per the Tender Document will lead to rejection of the bid.

SL. NO	PARTICULARS	PAGE NUMBER
1	Bidder Information	
2	Tender processing fee of Rs.1000/- by way of DD from any nationalized bank	
3	EMD (DD/BG) from a Nationalized Bank	
4	Proof of having supplied materials during the FY 12-13	
5	Certificates issued by the firm of CA's regarding turnover of the subject material	
6	Copy of ISO certification	
7	Satisfactory performance certificate from parties	
8	Constitution/legal status of the firm	
9	Copy of registration certificate	
10	Latest income tax returns filed	
11	VAT/CST registration	
12	Latest VAT/CST returns	
13	Power of attorney, wherever applicable	
14	List of machinery/equipment of the bidder	
15	Number of employees	
16	List of customers of previous supply of similar/ same items to IITs, NIT's or central universities or any academic institute of national repute institutions	
17	List of servicing facility centers or work shop with in India	
18	List of present clientele with contact addresses & telephone numbers	
19	The hard copies of all uploaded technical bid documents should be attested by the Gazetted officer and counter sign by bidder with seal	

20	All other information/documents that are required in bid documents	
----	--------------------------------------------------------------------	--

NOTE: All pages of the bid documents must be serially numbered and signed.